

BNC 50 Ohm Straight Twist-On Plug - Field Installable - 1 Piece

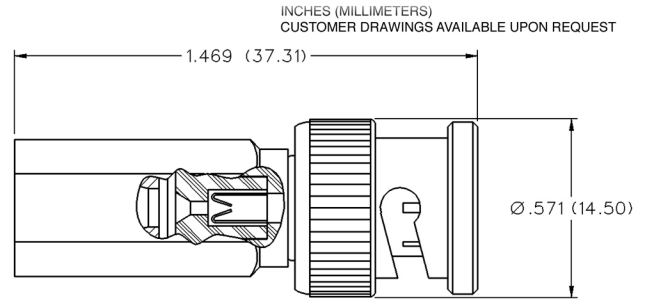

PART NUMBER	CABLE TYPE	CABLE CENTER CONDUCTOR	WIRE GAUGE	WIRE DECIMAL	JACKET O.D.
CPFI-UG88-1	RG-58	SOLID	22-18	.025 (.064)-.043 (1.09)	.185 (4.70)-.205 (5.21)

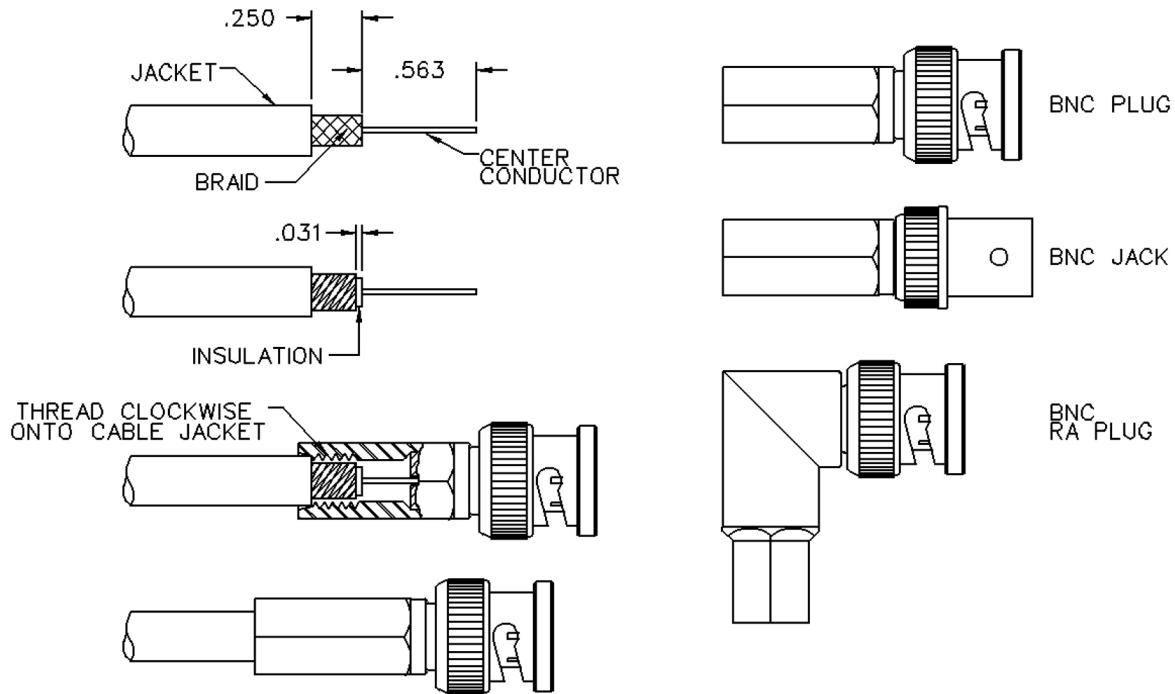

1. Identify connector parts. (1 piece)
2. Trim cable as shown. Taking care not to nick the center conductor or outer braid.
3. Use the fingernail to rotate the outer braids clockwise such that 1/32" of the insulation is bared. Then in the same direction rub the stray braids flat. (Stray or loose braids can cause shorts.)
4. Gently insert the center conductor down the back end of the connector, feeling it into the guide hole. (If the center conductor is not in place, approximately 1/8" of the center conductor - the part closest to the dielectric - will still be viewable.)
5. Firmly push the cable home (a slight clockwise twist may help with insertion). Then screw the connector on the cable in a clockwise direction until it is snugly attached to the jacket. (Right angle connectors provide a lever to aid in twist, therefore do not over twist, which may cause the jacket and braids to eventually wear out.)

CABLE ASSEMBLY CAUTIONS:

- Series are designed for solid center conductor wire. RG-58 cable will need the center conductor tin dipped (ONLY if it is not a solid center conductor). This is necessary to provide extra support for step 5.
- RG-MATV-59 cable will require caution when using the fingernail to rotate the braids on cable types that include aluminum foil for the outer conductor. DO NOT tear or rip the foil conductor to the 1/32" as suggested by step 3.
- RG-62 cable includes trimming the filament to 9/16" as well. Make sure that the filament does not unravel so that it protrudes past this dimension.

Part Number	Cable Type	Wire Gauge	Wire Decimal	Jacket O.D.
CPFI-UG88-1	RG-58	20	.032 (0.81)	.185 (4.07)-.205 (5.21)